

pvlab **ROBOT**
CREME

T U R B I N E S
TM15

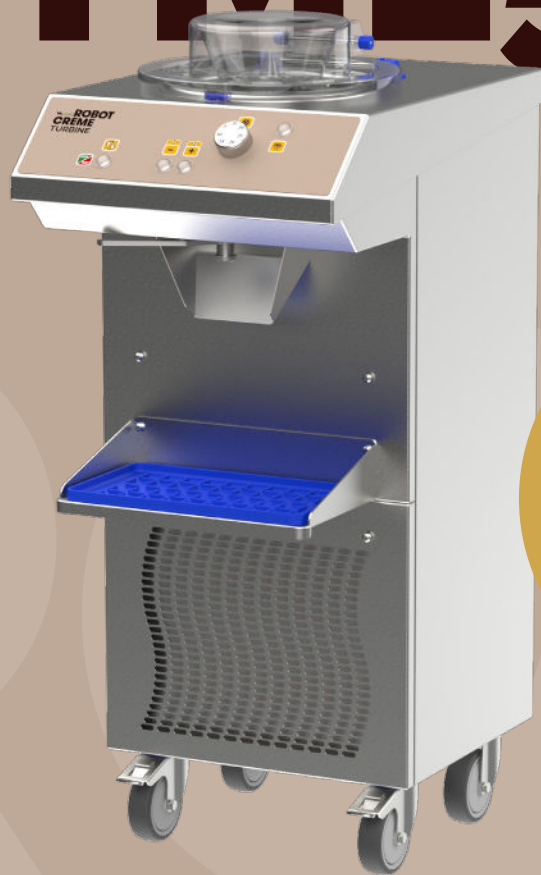

Avec nos Turbines, faites
entrer l'efficacité Robot Crème
dans votre production de
crèmes glacées et de sorbets.

TURBINES TM15



Turbine



- Commandes électromécaniques
- Compresseur hermétique «Bitzer»
- Refroidissement condenseur à air
- Carrosserie en acier inox AISI 304
- Isolation en polyuréthane sans CFC
- Gaz frigorigène R452a
- Sécurité pour l'arrêt de l'agitateur à l'ouverture du couvercle
- Extraction directe bas de cuve
- Dégivrage de la cuve par inversion de cycle gaz chaud

TABLEAU DE RECETTES

	Prod./H	Parcycle	Mini	Maxi
Crème glacée	15L	2L	1L	2L
Sorbets	15L	2L	1L	2L



Crème glacée



Sorbets



Poignée d'extraction en position fermée

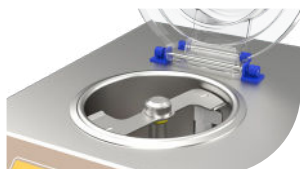

Cuve ouverte et bras de mélange

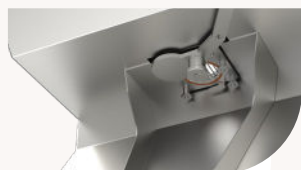

Poignée d'extraction en position ouverte

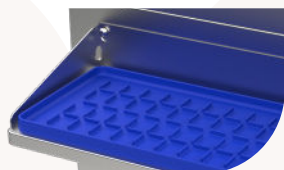

Plateau de maintien pour récipients

DONNÉES TECHNIQUES

Capacité de la cuve	5L
Production horaire (en sanglage continu)	15L/h
Puissance raccordée	2000W - 8,7A
Tension	230V ~ 50Hz
Dimensions LxPxH	43,5 x 60,5 x 107,2 cm 132,3 cm (couvercle ouvert)
Poids net	75 kg

BRAS DE MÉLANGE



SCHÉMA TECHNIQUE

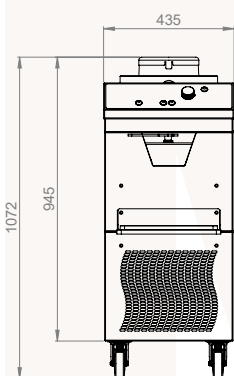

TABLEAU DE COMMANDES

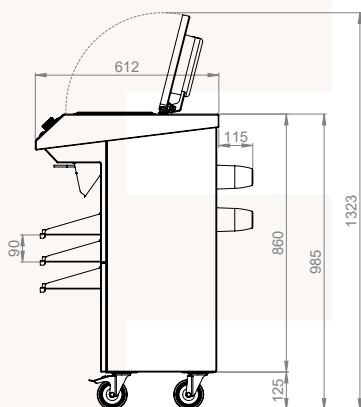